

Electronic Unit Controller

TABLE OF CONTENTS





<u>Section</u>	<u>Page</u>	<u>Section</u>	<u>Page</u>
Safety		2.6.1 Moving Parameters Between the Programming Menu and the Advanced Options Menu	7
Safety Instructions.....	2	2.7 Locking the Keypad.....	7
Safety Icon Explanation	2	2.8 Unlocking the Keypad	7
Instructions Pertaining to Risk of Electrical Shock, Fire, or Injury to Persons.....	3	2.9 Resetting the Alarm and Runtime Counters..	8
Safety Statements.....	3	3. Alarm Menu	8
1. Introduction and Features	4	4. Service Menu	8
1.1 Technical Specifications	5	5. Parameter List.....	9
1.2 Pressure Probe Error Bypass	5	6. Controller Wiring	10
1.3 Bump Start	5	6.1 Additional Controller Inputs	10
2. Installation and Controller Operation Instructions		7. Alarms/Notifications.....	11
2.1 Condensing Unit Installation Instructions	5	7.1 Discharge Line Temperature Protection	12
2.2 Controller Display.....	5	7.2 UL High Pressure Safety Control	12
2.3 Button Descriptions and Key Combinations....	6	8. Thermister Temperature Resistance Values ...	13-14
2.4 Viewing the Set Points	7	9. Troubleshooting Guide	15-16
2.5 Changing a Parameter Value	7		
2.6 Entering the Advanced Options Menu.....	7		







Safety Instructions

Copeland™ brand products are manufactured according to the latest U.S. and European Safety Standards. Particular emphasis has been placed on the user's safety. Safety icons are explained below and safety instructions applicable to the products in this bulletin are grouped on Page 3. These instructions should be retained throughout the lifetime of the compressor. **You are strongly advised to follow these safety instructions.**

Safety Icon Explanation

	DANGER indicates a hazardous situation which, if not avoided, will result in death or serious injury.
	WARNING indicates a hazardous situation which, if not avoided, could result in death or serious injury.
	CAUTION, used with the safety alert symbol, indicates a hazardous situation which, if not avoided, could result in minor or moderate injury.
	NOTICE is used to address practices not related to personal injury.
	CAUTION, without the safety alert symbol, is used to address practices not related to personal injury.

Instructions Pertaining to Risk of Electrical Shock, Fire, or Injury to Persons

	<p>ELECTRICAL SHOCK HAZARD</p> <ul style="list-style-type: none"> • Disconnect and lock out power before servicing. • Allow drive components to electrically discharge for a minimum of two minutes before servicing. • Use compressor with grounded system only. • Molded electrical plug must be used in all applications. • Refer to original equipment wiring diagrams. • Electrical connections must be made by qualified electrical personnel. • Failure to follow these warnings could result in serious personal injury.
	<p>PRESSURIZED SYSTEM HAZARD</p> <ul style="list-style-type: none"> • System contains refrigerant and oil under pressure. • Remove refrigerant from both the high and low compressor side before removing compressor. • Use appropriate back up wrenches on rotalock fittings when servicing. • Never install a system and leave it unattended when it has no charge, a holding charge, or with the service valves closed without electrically locking out the system. • Use only approved refrigerants and refrigeration oils. • Personal safety equipment must be used. • Failure to follow these warnings could result in serious personal injury.
	<p>BURN HAZARD</p> <ul style="list-style-type: none"> • Do not touch the compressor until it has cooled down. • Ensure that materials and wiring do not touch high temperature areas of the compressor. • Use caution when brazing system components. • Personal safety equipment must be used. • Failure to follow these warnings could result in serious personal injury or property damage.
	<p>COMPRESSOR HANDLING</p> <ul style="list-style-type: none"> • Use the appropriate lifting devices to move compressors. • Personal safety equipment must be used. • Failure to follow these warnings could result in personal injury or property damage.

Safety Statements

- Refrigerant compressors must be employed only for their intended use.
- Only qualified and authorized HVAC or refrigeration personnel are permitted to install, commission and maintain this equipment.
- Electrical connections must be made by qualified electrical personnel.
- All valid standards and codes for installing, servicing, and maintaining electrical and refrigeration equipment must be observed.

1. Introduction and Features

The introduction of the Electronic Unit Controller to Copeland™ brand condensing units will provide many benefits to the contractor and end-user. It has been designed specifically for demanding refrigeration applications to ensure precision in installation and operation. While the Electronic Unit Controller will replace existing adjustable low pressure controls, fan cycle switches and other relays, it also has additional features. These features include bump start (where applicable), data storage and short cycling protection (See **Figure 3**). This controller does NOT replace the fixed high pressure control required by UL.

The Electronic Unit Controller can be used on any condensing unit application with the appropriate sensors and relays that will be factory installed on the condensing unit. This document will explain how Electronic Unit Controllers affects your installation process and how it can also assist in troubleshooting if the need arises.

Controllers will be preprogrammed with the proper settings, resulting in little to no setup time. The unit will come with an attached label showing how to adjust the low pressure cut-in and cut out (See **Figure 1**). There will also be an additional label on the inside of the enclosure which will also list all of the factory default settings for the controller, including those that are not adjustable (See **Figure 2**). The inside label will also include a basic wiring diagram for the controller, basic

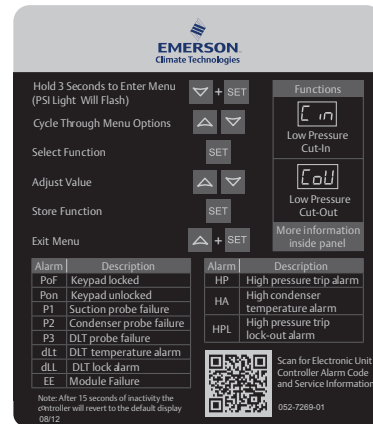

Figure 1

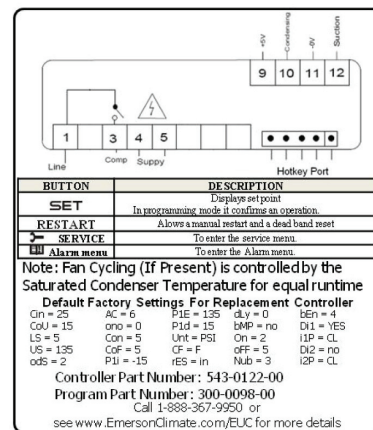

Figure 2









Features	Today	Dixell
Low Pressure Control 	Adjustable Mechanical Switch	Suction Pressure Transducer
High Pressure UL Safety Control 	Adjustable or Fixed Mechanical Switch	Fixed Mechanical Switch
Fan Cycling 	2 Mechanical Switches	Mid Coil Temperature Sensor
Time Delay 	Timing module	Built In
Discharge Line Protection 	Mechanical Thermostat	Temperature Sensor
Bump Start 	Timing Module	Built In
Multi-Refrigerant Approval 	2 Adjustable Mechanical Pressure Switches	Utilize Mid Coil Temperature Sensors
Data Storage 	Performance Alert*	Built In
Short Cycle Protection 	Performance Alert*	Built In

Figure 3

*Copeland PerformanceAlert is not replaced by the Electronic Pressure Control. The PerformanceAlert module includes many features not included in the Electronic Pressure Control, such as locked rotor protection, loss of phase, etc. The Electronic Pressure Control is able to interface with PerformanceAlert to display error codes in an easy-to-read format.

descriptions of what the buttons on the controller does, the controller part number and the part number for the pre-loaded program. A phone number to contact and a website for more information will be available on the inside label as well.

1.1 Technical Specifications

Mounting: Panel mounting in a 71x29mm panel cut-out

Controller IP Rating: IP20

Front Panel IP rating: IP65

Power supply: 208/230Vac ±10%, 50/60Hz
110Vac ±10%, 50/60Hz

Power absorption: 3VA max

Relay outputs:

Compressor Relay: 250VAC, 16A FLA, 96A LRA

Fan Relay 1: 250VAC, 4.9 FLA, 29.4 LRA

Fan Relay 2: 250VAC, 1.9 FLA, 11.4 LRA

Special Note: EUC fan cycling relays are not approved for use with ECM motors

Data storage: Non-volatile memory (EEPROM).

Rated impulsive voltage: 2500V; Overvoltage Category: II

Factory Installed Operating Range: -40 – 120°F Ambient

Non-Factory Installed Operating Range: -4 to 120°F Ambient

1.2 Pressure Probe Error Bypass

The pressure probe bypass is in place to allow the controller to run proper during pull down if a system has been off for a period of time and the suction pressure is greater than the maximum value the suction transducer can read (In most cases, 135 PSIG). If this occurs, the controller will flash the maximum value of the transducer for 15 minutes or until the suction pressure is pulled down below the maximum transducer value. The compressor will run continuously during this time unless the thermostat input or high pressure input are opened, or if there is a discharge line temperature trip. If the 15 minutes expires the pressure probe error P1

is signaled and the compressor is switched on and off cyclically with t_{on} (default 5 minutes) and t_{off} (default 5 minutes) period.

1.3 Bump Start

Bump start is an optional feature which can provide additional flooded start protection. The compressor is turned on for 2 seconds, then turned off for 5 seconds 3 times before the compressor runs normally. This allows for refrigerant to exit the compressor without the oil being removed as well.

Bump start is enabled on all transport units, without the ability to be turned off. On most stationary units, it is turned off by default, but can be turned on in the Advanced Options Menu as by changing $bump$ to Yes. (See section 2.6).

2. Installation and Controller Operation Instructions

2.1 Condensing Unit Installation Instructions

A condensing unit with an Electronic Unit Controller will be installed exactly the same as a condensing unit with mechanical controls. Customer connections will not change, and in a vast majority of cases, wiring to the unit will not change as well. See section 6 for more information. The key difference with an Electronic Unit Controller is that setpoints are set electronically rather than mechanically. See section 2.5 for further details.

If the unit keeps shutting down during charging, the low pressure cut out can be lowered to allow it to run. Be sure to adjust it back to the proper setting after charging.

2.2 Controller Display

The controller display is shown in Figure 4 below. **Table 1** provides a description of each of the labeled lights. The controller is defaulted to display the current suction pressure to three significant digits in pounds per square inch gage (psig).

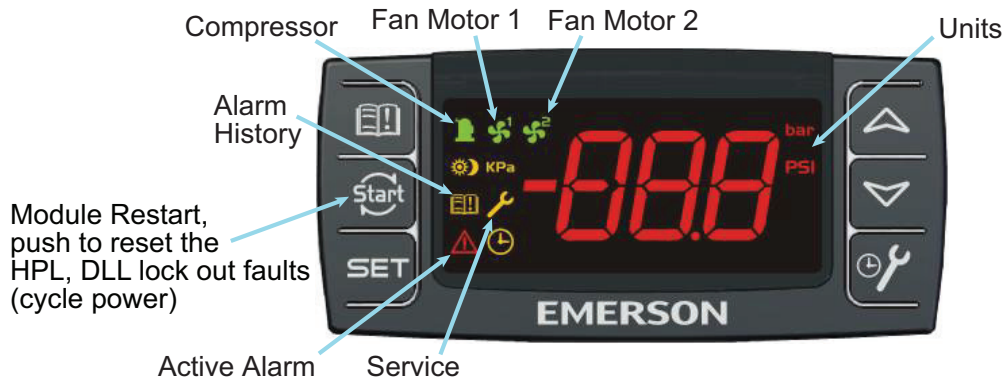









Figure 4

Table 1 – LED Descriptions

LED	MODE	FUNCTION
	ON	Compressor On
	Flashing	Anti-short cycle delay enabled
	ON	Fan1 On
	ON	Fan 2 On
PSI	ON	Pressures displayed in PSIG
PSI	Flashing	Programming mode
	ON	Browsing the service menu
	Flashing	New alarm indication
	ON	You're browsing the alarm menu
	ON	An alarm is occurring

2.3 Button Descriptions and Key Combinations

Table 2 lists the different buttons on the controller (as shown in **Figure 4**) as well as their functions. **Table 3** lists the different key combinations that are available and their functions.

Table 2 – Button Descriptions









BUTTON	DESCRIPTION
SET	Displays set point In programming mode it confirms an operation.
START	1) To override the cut-in value push the start function button (see Figure 4) for 3 seconds. Compressor will then start. 2) If a DLL or HPL lock out condition occurs, to reset depress the start button (see Figure 4) for 3 seconds two consecutive times to reset the lock out condition. (If the temperatures or pressures are exceeding the cut out trip point values, pushing the start button will not clear the fault)
 (UP)	In programming mode it browses the parameter codes or increases the displayed value.
 (DOWN)	In programming mode it browses the parameter codes or decreases the displayed value.
 SERVICE	To enter the service menu. (See Section 4)
 Alarm menu	To enter the Alarm menu. (See Section 3)

Table 3 – Key Combinations

KEY COMBINATIONS:	
 + 	To lock & unlock the keyboard interface
SET + 	To enter into programming mode.
SET + 	To return to the suction pressure display.





2.4 Viewing the Set Points:



1. Push and immediately release the **SET** key: the display will show the “**└┐**” message.
2. Press **SET** to see the value;
3. Push and immediately release the **SET** key: the display will show the “**└┐**” message.
4. Press **SET** to see the value.

2.5 Changing a parameter value:

To change the parameter’s value, operate as follows:







1. Hold down the **SET** +  keys for 3 seconds or until the “**PSI**” LED starts blinking to enter the module’s programming menu.
2. Use  or  to select the required parameter. Press the **SET** key to display its value.
3. Use  or  to change its value.
4. Press **SET** to store the new value.

TO EXIT: Press **SET** +  or wait 15 seconds without pressing a key.

NOTE: the set value is stored even when the procedure is exited by waiting for the time-out to expire.

2.6 Entering the Advanced Options Menu:

The advanced options menu will be locked 5 minutes after the controller is powered. If you need to access this menu after this time, cycle power to the controller.

1. Enter the Programming mode by pressing the **SET** +  keys for 3 seconds (the **PSI** LED starts blinking).
2. Release the keys, then push again the **SET** +  keys for at least 7 seconds. The Pr2 label will be displayed immediately followed from the **└┐** parameter.
NOW YOU ARE IN THE ADVANCE OPTIONS MENU.
3. Use  or  to select the required parameter.
4. Press the **SET** key to display its value.
5. Use  or  to change its value.
6. Press **SET** to store the new value.

TO EXIT: Press **SET** +  or wait 15 seconds without pressing a key.

NOTE1: if no parameter is present in Pr1, after 3 seconds the “noP” message is displayed.

Keep the keys pushed until the Pr2 message is displayed.

NOTE2: the set value is stored even when the procedure is exited by waiting for the time-out to expire.



2.6.1 Moving Parameters between the Programming Menu and the Advanced Options Menu

While in the advanced options menu, certain parameters will have a (. period) in between the 2nd and 3rd character, for example **└┐**. These parameters are in the Programming Menu as well as the Advanced Options Menu.



To add or remove a parameter from the programming menu, press the **SET** +  keys together while the parameter name is on the display in the advanced options menu. The (. period) between the 2nd and 3rd parameter will either be added or removed.

To Exit: Press **SET** +  or wait 15 seconds without pressing the keys.

2.7 Locking the Keypad

1. Keep pressed for more than 3 seconds the  +  keys.
2. The “POF” message will be displayed and the keyboard will be locked. At this point it will be possible only to see the set points.
3. If a key is pressed more than 3 seconds the “POF” message will be displayed.



2.8 Unlocking the Keypad

Keep pressed together for more than 3 seconds the  +  keys, until the “Pon” message is displayed.



2.9 Resetting the Alarm and Runtime Counters

See sections 3 and 4 for more information on the Alarm and Service Menus.

The advanced options menu will be locked 5 minutes after the controller is powered. If you need to reset counters after this time, cycle power to the controller.

1. Enter the Programming mode by pressing the **SET** +  keys for 3 seconds (the **PSI** LED starts blinking).
2. Release the keys, then push again the **SET** +  keys for more than 7 seconds. The Pr2 label will be displayed immediately followed from the “[n]” parameter.

NOW YOU ARE IN THE ADVANCE OPTIONS MENU.

3. Use  or  to select the required parameter listed below.

rSA – Reset Alarm Counters (*HP*, *dLT*, and *Loc*)

rCA – Reset Compressor Starts Counters

rCH – Reset Compressor Run Hours Counters

rFH – Reset Fan Run Hours Counters

4. Press the **SET** key to display its value.
5. Use  Change the *n* to *4*.
6. Press **SET** to store the new value and reset the counter
7. Repeat steps 3 to 6 to reset any additional counters

3. Alarm Menu

The controller records in the Alarm menu the total number of activations of the following alarms.

- High Pressure Trips (up to 999) - *HP*.
- High DLT temperature alarm (up to 999) - *dLT*.
- Total number of manual restarts (HPL and dLL) up to 255 - *LOC*.

To see the alarm counters:

1. Push and release the  key.
2. The controller shows the *HP* label.
3. Push the **SET** key to see the number of high pressure trips.
4. The controller shows the *dLT* label.
5. Push the **SET** key to see the number of DLT Trips.
6. The controller shows the *Loc* label.
7. Push the **SET** key to see the number of manual resets.

4. Service Menu

In the **SERVICE** menu the following values are stored:

- **Number of compressor starts:** *SEH* (0-999 resolution 1000); *SEL* (0-999 resolution 1)
Example: If *SEH* = 12 *SEL* = 500: the total number of compressor starts = 12,500
- **Compressor Run Hours:** *CHH* (0-65; res. 1000) *CHL* (0- 999; res. 1);
Example: If *CHH* = 8 and *CHL* = 500, the total number of compressor run hours is 8,500
- **Fan Motor 1 Run Hours:** *F1H* (0-65; res. 1000) *F1L* (0-999; res. 1)
- **Fan Motor 2 Run Hours:** *F2H* (0-65; res. 1000) *F2L* (0-999; res. 1);

To see the Service Counters:

1. Push and hold the  key for 3 seconds
2. See the above list for the counter names and meanings.

5. Parameter List

All of the parameters are listed below, along with their descriptions and default values. Depending on the condensing unit model, some of these values may be different or not applicable.

Table 4 – Parameters

Label	Description	Default	Range
Default Display Value			
	Current Suction Pressure (PSIG)		
Adjustable In Programming Menu			
<i>C_{in}</i>	Compressor cut in (PSIG)	25	<i>C_{oU} - U5</i>
<i>C_{oU}</i>	Compressor cut out (PSIG)	15	<i>L5 - C_{in}</i>
Adjustable From Advanced Options Menu			
<i>odS</i>	Outputs delay at start up (seconds) (Only adjustable on single phase scroll units)	2 or 4	2 - 255
<i>AC</i>	Anti-short cycle delay (Minimum time between compressor off then on) (seconds)	6	6 - 900
<i>C_{on}</i>	Compressor ON time with faulty probe (minutes)	5	0-255
<i>C_{oF}</i>	Compressor OFF time with faulty probe (minutes)	5	0-255
<i>P_{IF}</i>	Suction Pressure Transducer Offset (PSI)	0	- 120 - 120
<i>b_{TP}</i>	Bump start enabled	no	no - YES
<i>n_{PS}</i>	Number of activation of DLT alarm in a hour to lock compressor (Units with discharge line temperature protection only)	4	0- 15; 0 = always automatic restart
<i>HP_n</i>	UL safety digital input activation before compressor lock (Units with fixed high pressure controls only)	5	0- 15; 0 = always automatic restart
<i>SF₁</i>	Fan 1 Cut Out (°F) (Fan Cycling Units Only)	70	-40 - <i>SF₂</i>
<i>HF₁</i>	Fan 1 differential (°F) (Fan Cycling Units Only)	10	1 - 100
<i>SF₂</i>	Fan 2 Cut Out (°F) (Fan Cycling Units Only)	85	<i>SF₁ - 230</i>
<i>HF₂</i>	Fan 2 differential (°F) (Fan Cycling Units Only)	15	1 - 100
<i>r_{SA}</i>	Reset Alarm Counters (<i>HP</i> , <i>dLT</i> , and <i>Lac</i>)		
<i>r_{CA}</i>	Reset Compressor Starts Counters		
<i>r_{CH}</i>	Reset Compressor Run Hours Counters		
<i>r_{FH}</i>	Reset Fan Run Hours Counters (Fan Cycling Units Only)		
Factory Set Definitions			
<i>L5</i>	Minimum set point (PSIG)	-7 or 5	-7 - U5
<i>U5</i>	Maximum set point (PSIG)	135	L5 - 135
<i>ono</i>	Minimum time between two compressor starts (minutes)	0	0 - 15
<i>n_{FA}</i>	Number of fans on during probe fault	2	0 - 2
<i>U_{nt}</i>	Measurement unit for pressure: PSIG, bar, kPA	PSI	PSI, bAr, HPA
<i>CF</i>	Measurement unit for temperature	F	°C or °F
<i>on</i>	Bump Start Compressor on time (seconds)	2	1 - 15
<i>oFF</i>	Bump Start Compressor off time (seconds)	5	1 - 15
<i>n_{Ub}</i>	Number of cycle during bump start	3	1 - 15
<i>bE_n</i>	Compressor stop time for next bump start (hours)	4.0	1.0 - 23.5
<i>doF</i>	DLT alarm temperature to stop compressor (°F)	220	<i>don</i> - 302
<i>don</i>	DLT temperature for compressor restart (°F)	170	-58 - <i>doF</i>
<i>AL_d</i>	DLT Stop compressor delay (seconds)	0	0 - 255
<i>dLF</i>	Minimum time of compressor off with dLL alarm (minutes)	0	0 - 15
<i>AU₂</i>	Cut In for Condenser Temperature/Pressure alarm (°F)	150	<i>AH₂ - 230</i>
<i>AH₂</i>	Cut Out for high Condenser Temperature/Pressure alarm (°F)	140	-40 - <i>AU₂</i>
<i>Rd₂</i>	High condenser temperature alarm delay (minutes)	0	0 - 255
<i>HPF</i>	Minimum off time after a High Pressure Trip (minutes)	5	0 - 15

6. Controller Wiring



Always disconnect and lockout the power supply before beginning electrical installations or troubleshooting.

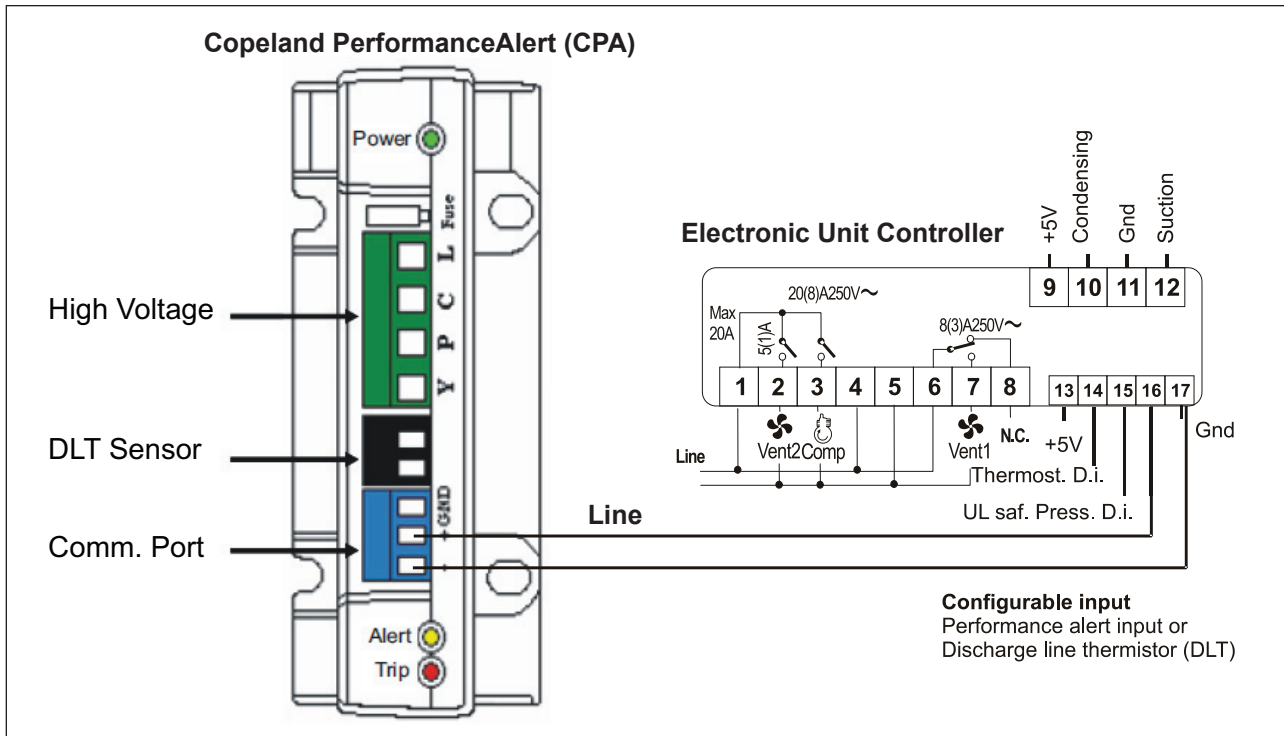

Figure 5 – Wiring Schematic Example for the Electronic Unit Controller with Copeland PerformanceAlert

Suction Pressure Transducer: Use terminal 9 (+5V) for supply, terminal 11 for ground and terminal 12 for signal

Condenser Temperature Sensor: Connect the probe to terminal 11 (ground) and 10

Thermostat input: use terminals 14-17

UL HP input: use terminals 15-17

DLT Sensor: Connect the probe to terminals 16-17

Copeland Performance Alert (CPA) connection: Connect the CPA as shown in the wiring diagram.

For more information on PerformanceAlert, see Application Engineering Bulletin **AE8-1347**.

Power supply: use terminals 4-5

Compressor: use terminals 1-3

FAN 1: use terminals 6-7

FAN 2: use terminals 1-2

6.1 Additional Controller Inputs

If any other devices are used to control the condensing unit, such as a thermostat or other type device, it will need to be a dry contact (no voltage) and will need to be connected to terminals 14 and 17. These terminals are located on the hotkey cable. These two terminals will be connected together by push-on type connectors allowing for ease of performing the final connection. See **Figure 5** for wiring details.

NOTE: If using a controller such as a thermostat with another device such as a pump down solenoid, no connections to the controller are required.

7. Alarms/Notifications

In the event of an issue, the below codes will flash to indicate the alarm condition. See **Section 9, Troubleshooting Guide**, for further instruction.

Table 5 – Alarms And Notifications

Code	Description
<i>PoF</i>	Keypad locked
<i>POn</i>	Keypad unlocked
<i>P1</i>	Suction probe failure
<i>P2</i>	Condenser probe failure
<i>P3</i>	DLT probe failure
<i>HR</i>	High condenser temperature alarm
<i>dLt</i>	DLT temperature alarm
<i>dLL</i>	DLT lock alarm
<i>HP</i>	High pressure trip alarm
<i>HPL</i>	High pressure trip lock-out alarm
<i>CPR</i>	Copeland PerformanceAlert not connected properly
<i>EE</i>	Module Failure

If a Copeland PerformanceAlert is installed in the unit, any error codes from the PerformanceAlert will be displayed on the screen of the Dixell controller. This eliminates the need to count light flashed on the PerformanceAlert itself. For more information on PerformanceAlert, see **AE8-1347**.

Table 6 – Copeland PerformanceAlert Error Codes

Code	Three Phase Recip	Three Phase Scroll	Single Phase
<i>C01</i>	Discharge Temperature Trip	Discharge Temperature Trip	Discharge Temperature Trip
<i>C02</i>	System Trip	System Trip	System Trip
<i>C03</i>	Short Cycling	Short Cycling	Short Cycling
<i>C04</i>	Locked Rotor	Locked Rotor	Locked Rotor
<i>C05</i>	Open Circuit	Open Circuit	Open Circuit
<i>C06</i>	Missing Phase	Missing Phase	Open Run
<i>C07</i>	NA	Reverse Phase	Open Start
<i>C08</i>	Welded Contactor	Welded Contactor	Welded Contactor
<i>C09</i>	Low Voltage	Low Voltage	Low Voltage
<i>C10</i>	Lost communications	Lost communications	Lost communications
<i>C11</i>	DLT Sensor Failure	DLT Sensor Failure	DLT Sensor Failure

7.1 Discharge Line Temperature Protection

Discharge line temperature protection has traditionally been handled by a mechanical thermostat, which was always an automatic reset, and other than the system not running, gave no indication that a trip had occurred or is occurring. The Electronic Unit Controller uses a temperature sensor, which allows for more flexibility in what the controller can do. If the unit trips, the unit will display an error code and log that an error has occurred. In addition, the controller will allow an automatic reset up to 4 times per hour. On the fourth trip, the controller will require a manual reset. The parameter nPS can be changed in the Advanced Options Menu (see section 2.6) to adjust the total number of trips allowed in an hour before a lockout. If an always automatic reset is needed, then nPS can be set to 0. The default value for the discharge line cut-out is 220°F and the cut-in is 170°F.

7.2 UL High Pressure Safety Control

High pressure control is a UL safety device. As such, Emerson Climate Technologies condensing units equipped with the Electronic Unit Controller still come with the high pressure mechanical control installed on the unit. The high pressure controls will all be fixed to work with the control, and the value of the cut-out will be determined by the working pressure of the high side of the condensing unit. This should have no effect on a customer's UL requirements.

The high pressure control will break power to the compressor output relay, which will shut down the compressor regardless of the program state. This change will also allow the controller to read the high pressure control state, and display the appropriate error codes as needed. In addition, the controller will allow an automatic reset up to 4 times per hour. On the fifth trip, the controller will require a manual reset. The parameter HPn can be changed in the Advanced Options Menu (See section 2.6) to adjust the total number of trips allowed in an hour before a lockout. If an always automatic reset is needed, then HPn should be set to 0.

8. Thermister Temperature/Resistance Values for Condenser Temperature Sensor

Deg C	Deg F	Resistance (kOhms)
-50	-58	329.5
-49	-56	310.9
-48	-54	293.5
-47	-53	277.2
-46	-51	262
-45	-49	247.7
-44	-47	234.3
-43	-45	221.7
-42	-44	209.9
-41	-42	198.9
-40	-40	188.5
-39	-38	178.5
-38	-36	169
-37	-35	160.2
-36	-33	151.9
-35	-31	144.1
-34	-29	136.7
-33	-27	129.8
-32	-26	123.3
-31	-24	117.1
-30	-22	111.3
-29	-20	105.7
-28	-18	100.5
-27	-17	95.52
-26	-15	90.84
-25	-13	86.43
-24	-11	82.26
-23	-9	78.33
-22	-8	74.61
-21	-6	71.1
-20	-4	67.77
-19	-2	64.57
-18	0	61.54
-17	1	58.68
-16	3	55.97
-15	5	53.41
-14	7	50.98
-13	9	48.68
-12	10	46.5
-11	12	44.43
-10	14	42.47
-9	16	40.57

Deg C	Deg F	Resistance (kOhms)
-8	18	38.77
-7	19	37.06
-6	21	35.44
-5	23	33.9
-4	25	32.44
-3	27	31.05
-2	28	29.73
-1	30	28.48
0	32	27.28
1	34	26.13
2	36	25.03
3	37	23.99
4	39	23
5	41	22.05
6	43	21.15
7	45	20.3
8	46	19.48
9	48	18.7
10	50	17.96
11	52	17.24
12	54	16.56
13	55	15.9
14	57	15.28
15	59	14.69
16	61	14.12
17	63	13.58
18	64	13.06
19	66	12.56
20	68	12.09
21	70	11.63
22	72	11.2
23	73	10.78
24	75	10.38
25	77	10
26	79	9.632
27	81	9.281
28	82	8.944
29	84	8.622
30	86	8.313
31	88	8.014
32	90	7.728
33	91	7.454

Deg C	Deg F	Resistance (kOhms)
34	93	7.192
35	95	6.94
36	97	6.699
37	99	6.467
38	100	6.245
39	102	6.032
40	104	5.827
41	106	5.629
42	108	5.438
43	109	5.255
44	111	5.08
45	113	4.911
46	115	4.749
47	117	4.593
48	118	4.443
49	120	4.299
50	122	4.16
51	124	4.026
52	126	3.896
53	127	3.771
54	129	3.651
55	131	3.536
56	133	3.425
57	135	3.318
58	136	3.215
59	138	3.116
60	140	3.02
61	142	2.927
62	144	2.838
63	145	2.751
64	147	2.668
65	149	2.588
66	151	2.511
67	153	2.436
68	154	2.364
69	156	2.295
70	158	2.228
71	160	2.163
72	162	2.1
73	163	2.039
74	165	1.98
75	167	1.924

Deg C	Deg F	Resistance (kOhms)
76	169	1.869
77	171	1.816
78	172	1.765
79	174	1.716
80	176	1.668
81	178	1.621
82	180	1.577
83	181	1.533
84	183	1.491
85	185	1.451
86	187	1.411
87	189	1.373
88	190	1.336
89	192	1.3
90	194	1.266
91	196	1.232
92	198	1.2
93	199	1.168
94	201	1.137
95	203	1.108
96	205	1.079
97	207	1.051
98	208	1.024
99	210	0.9984
100	212	0.9731
101	214	0.9489
102	216	0.9246
103	217	0.9014
104	219	0.8789
105	221	0.8572
106	223	0.836
107	225	0.8155
108	226	0.7956
109	228	0.7763
110	230	0.7576

8.1 Thermister Temperature/Resistance Values for Discharge Temperature Sensor

Deg C	Deg F	Resistance (kOhms)
-40	-40	2889.60
-35	-31	2087.22
-30	-22	1522.20
-25	-13	1121.44
-20	-4	834.72
-15	5	627.28
-10	14	475.74
-5	23	363.99
0	32	280.82
5	41	218.41
10	50	171.17
15	59	135.14
20	68	107.44
25	77	86.00
30	86	69.28
35	95	56.16
40	104	45.81
45	113	37.58
50	122	30.99
55	131	25.68
60	140	21.40
65	149	17.91

Deg C	Deg F	Resistance (kOhms)
70	158	15.07
75	167	12.73
80	176	10.79
85	185	9.20
90	194	7.87
95	203	6.77
100	212	5.85
105	221	5.09
110	230	4.45
115	239	3.87
120	248	3.35
125	257	2.92
130	266	2.58
135	275	2.28
140	284	2.02
145	293	1.80
150	302	1.59
155	311	1.39
160	320	1.25
165	329	1.12
170	338	1.01
175	347	0.92
180	356	0.83

9. Troubleshooting Guide

Display	Likely Causes	Other Possible Causes
Controller display remains blank after applying power	<ul style="list-style-type: none"> • Unit power not properly applied - check for proper applied voltage • Power cable harness not plugged in properly or securely into the back of the controller – check connections 	<ul style="list-style-type: none"> • Power cable miswired – inspect cable, replace if needed • Electrical assembly miswired – trace wiring diagrams
Controller displays correctly, but the green compressor light is off and the compressor is not running	<ul style="list-style-type: none"> • Jumper cable not plugged in properly or securely into the back of the controller – check connections • Controller is currently above the cut-in setting – check cut-in and cut-out settings 	<ul style="list-style-type: none"> • Jumper cable miswired – inspect cable, replace if needed
Controller displays correctly and the green compressor light is on and the compressor is not running	<ul style="list-style-type: none"> • Power cable harness not plugged in properly or securely into the back of the controller – check connections 	<ul style="list-style-type: none"> • Power cable not wired to the contactor or compressor correctly, check wiring • Power cable miswired – inspect cable, replace if needed
Controller flashes “135” or “P1”	<ul style="list-style-type: none"> • Current system pressure is above 135 PSIG – wait for system to pull down • Green harness not plugged in properly or securely into the back of the controller – check connections • Cable not connected properly with the pressure transducer – check connections 	<ul style="list-style-type: none"> • Transducer cable miswired – inspect cable, replace if needed • Damaged transducer – inspect transducer, replace if needed
Controller flashes “P2” on a unit with fan cycling	<ul style="list-style-type: none"> • Green harness not plugged in properly or securely into the back of the controller – check connections 	<ul style="list-style-type: none"> • Transducer cable miswired – inspect cable, replace if needed • Check condenser temperature sensor resistance values against table in Section 8.
Controller flashes “P2” on a unit without fan cycling after replacing a controller	<ul style="list-style-type: none"> • Controller not programmed properly – check parameters in the advanced menu 	
Controller flashes “P3” on a unit with DLT	<ul style="list-style-type: none"> • Jumper cable not plugged in properly or securely into the back of the controller – check connections 	<ul style="list-style-type: none"> • Jumper cable miswired – inspect cable, replace if needed • Faulty DLT temperature sensor – check the discharge line temperature sensor resistance values against table in Section 8.
Controller flashes “P3” on a unit without DLT after replacing a controller	<ul style="list-style-type: none"> • Controller not programmed properly – check parameters in the advanced menu 	

Troubleshooting Guide (continued)

Display	Likely Causes	Other Possible Causes
Fans not running on a fan cycling unit and the fan lights are not on	<ul style="list-style-type: none"> • Condensing temperature is currently below the fan cut-in • Condensing temperature sensor not properly installed – check installation 	<ul style="list-style-type: none"> • Transducer cable miswired – inspect cable, replace if needed • Faulty temperature sensor - check condenser temperature sensor resistance values against table in Section 8.
Fans not running on a fan cycling unit and the fan lights are on	<ul style="list-style-type: none"> • Power cable harness not plugged in properly or securely into the back of the controller – check connections 	<ul style="list-style-type: none"> • Power cable miswired – inspect cable, replace if needed • Electrical assembly miswired – trace wiring diagrams
Controller flashes “HP” at power-up	<ul style="list-style-type: none"> • Jumper cable not plugged in properly or securely into the back of the controller – check connections • High pressure switch is seeing above the cut-out pressure • For a replacing an -00 controller, ensure that the jumper cable is the latest revision. It should have a blue wire in the harness. See replacement instructions for more details. 	<ul style="list-style-type: none"> • Jumper cable miswired – inspect cable, replace if needed • Faulty fixed Hp switch – inspect switch, replace if needed
Controller flashes “HP” or “HPL”	<ul style="list-style-type: none"> • System operation causing high discharge pressures, check system operations 	<ul style="list-style-type: none"> • Bad high pressure switch, verify system pressure when the pressure switch trips. • See Section 7.2 for more details.
Controller flashes “DLT” or “DLL”	<ul style="list-style-type: none"> • System operation causing high discharge line temperatures, check system operations 	<ul style="list-style-type: none"> • Faulty temperature sensor - check DLT sensor values against table in section 8. • See Section 7.1 for more details
Controller flashing “HPL” or “DLL”	<ul style="list-style-type: none"> • System operation causing high discharge pressures (HPL) or high discharge line temperatures (DLL) repeatedly, check system operations • To clear an “HPL” or “DLL” lockout, you can hold the Restart button for 3 seconds twice, or cycle power to the unit. If using the reset button, the alarm condition will have to clear (DLT temperature drops or Hp switch resets), and any minimum off time will need to complete (5 minutes for the fixed Hp switch) 	

The contents of this publication are presented for informational purposes only and are not to be construed as warranties or guarantees, express or implied, regarding the products or services described herein or their use or applicability. Emerson Climate Technologies, Inc. and/or its affiliates (collectively "Emerson"), as applicable, reserve the right to modify the design or specifications of such products at any time without notice. Emerson does not assume responsibility for the selection, use or maintenance of any product. Responsibility for proper selection, use and maintenance of any Emerson product remains solely with the purchaser or end user.